



# PBA 60H

User Manual / Version 1.2



## SAFETY INSTRUCTIONS

1. Read this manual carefully.
2. Follow all instructions and warnings.
3. Only use accessories specified by WORK PRO.
4. Follow the safety instructions of your country.
5. Be careful with sound levels.

## SYMBOLS

The following symbols are used in this document:



This symbol indicates a potential risk of harm to a person or damage to the product. You can also notify the user of the instructions that must be followed strictly to ensure the installation or safe operation of the product.



This symbol notifies the user about the instructions that must be followed strictly to ensure the correct installation or operation of the product.



This symbol notifies the user about additional information or optional instructions.

## WELCOME TO WORK PRO

Thank you for choosing the WORK PRO PBA 60H system.

This document contains essential information on the use of the system. Read this document carefully to become familiar with the system.

Please check the WORK PRO website regularly to download the latest version of the document:  
<https://www.workpro.es/>

---

## CONTENT

1. INTRODUCTION.....	3
2. CONNECTIONS & FUNCTIONS.....	4
2.1. Front view.....	4
2.2. Rear view.....	5
3. OUTPUT CONNECTIONS.....	6
3.1. STEREO.....	6
3.2. MONO.....	6
3.3. BRIDGE.....	6
4. COMMUNICATION PROTOCOL & COMMANDS.....	7
5. ACCESSORIES.....	9

## 1. INTRODUCTION

PBA 60H is an ultra-compact 2x20W amplifier (@4 ohm) that has several input sources: 2 stereo Line + 1 input that can be microphone or Line. It includes tone control (low and high) and output gain controls. Both, the source selection and tone and gain control, are performed either manually with the small buttons on the chassis or via RS232 remote control. It also has both remote and manual mute control. The mic input can be with selectable phantom power or it can change its function to Line input.

It has a stereo audio output with up to 2x20W @ 4 ohm or 1x40W @ 8 ohm in bridge mode. Additionally, it has a Line output to feed another amplifier signal.

It is powered at 24V DC making it compatible with the **BL PS60**. The chassis is the same as the used by BlueLine devices, so it can be mounted on the wall or it can use the **BL AR19** accessory to rack up to 4 units in a single rack unit, forming a stack of amplifiers up to 8x20W.

### Features:

- 2x20W @ 4 ohm / 1x40W @ 8 ohm (bridge mode) power output.
- Two stereo audio inputs (2 x RCA and 3.5mm minijack), selectable by button and RS232.
- One balanced input with MIC+PHANTOM, MIC or LINE configuration.
- MIC input / Line inputs / Bass / Treble levels adjustable by buttons and RS232.
- LOOP audio output to supply signal to another amplifier (3.5 mm minijack).
- Stereo, Mono and Bridge configurations selectable from a switch.
- Balanced input mixes its signal with the other input selected.
- Both balanced and stereo inputs levels are controlled separately.
- No extra cooling needed.



**24VCD, 2A power supply not included.**

## 2. CONNECTIONS & FUNCTIONS

### 2.1. Front view

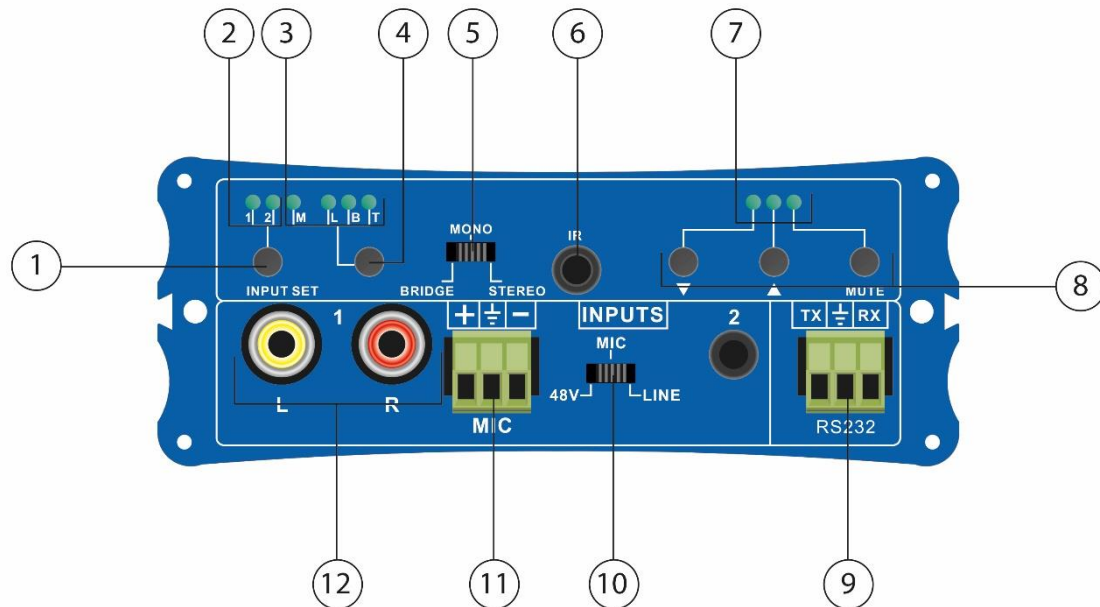

1. **INPUT SET pushbutton.** Use this button to select between Line Input 1 (RCA connection) or Line Input 2 (3.5 mm jack).



In both cases MIC input is active and mixes its signal with the Line input selected.

2. **Input selection LEDs:** The corresponding LED will light according to the selection (1).
3. **M/L/B/T selection LEDs:** The corresponding LED will light according to the selection (4).
4. **M/L/B/T pushbutton.** Use this button to select the parameter level you want to increase or decrease using UP and DOWN pushbuttons (8).  
M: Mic Input selection.  
L: Line Input Selection.  
B: Bass selection.  
T: Treble selection.
5. **BRIDGE / MONO / STEREO selector.** This control determines how the input mixing is used by the amplifier.  
**STEREO:** it is the normal behaviour. Line input selected (stereo) and MIC input (mono) are mixed and sent to output.  
**MONO:** Line input selected (stereo) and MIC input (mono) are added (decreasing 6 dB each stereo input) and sent to output.  
**BRIDGE:** same as MONO but one channel is reversed to obtain at the output double voltage (4 times power output).
6. **IR input:** Disabled.

7. **UP/DOWN/MUTE LEDs:** The corresponding LED will light according to the selection (8,9).
8. **UP / DOWN / MUTE:** By combining these buttons with M/L/B/T the user can modify levels. MUTE: This pushbutton mutes and unmutes output.
9. **RS232:** Use this connector to apply a RS232 signal from a host device.  
RX: signal from command sender.  
TX: signal to send feedback to command sender.



See chapter 4 for Communications protocol and Commands used.



Don't forget to join GND signal to GND of command sender.

10. **48V / MIC / LINE SELECTOR:** This switch allows to select the input (11). This input can be used for electret or dynamic microphones or with Line signals (in this case, sensitivity is greater than normal Line inputs). All cases, user can use balanced signals reducing the amount of noise that appears as external influence at the cables.
11. **INPUT 2 Connection:** Connect the audio signal, considering the polarity.



It is recommended that if you are not going to use this input, turn its gain level down to minimum to avoid unwanted noise.

12. **INPUT 1 Connection:** Connect a Line level audio signal.

## 2.2. Rear view

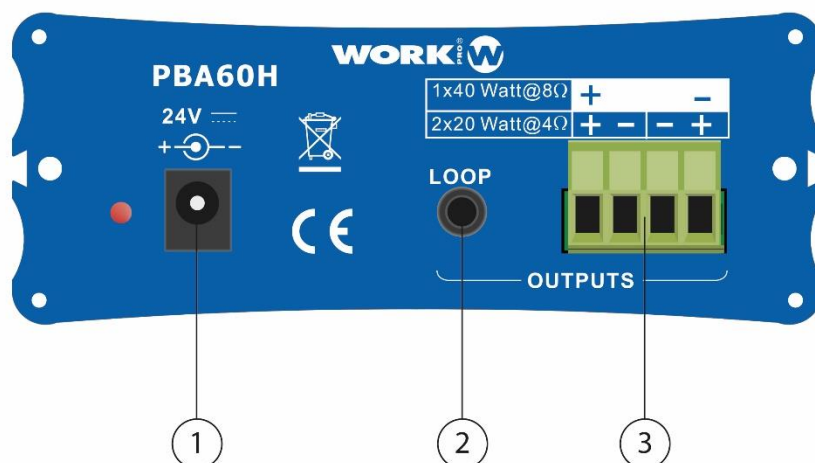

1. **DC Input:** Connect the 24VDC, 2A power supply. Not included
2. **LOOP:** You can use this mixed output as monitor signal.

3. **OUTPUTS:** Connect the loudspeakers considering the mode (Stereo, Mono or Bridge), the total impedance and the correct polarity.

### 3. OUTPUT CONNECTIONS

#### 3.1. STEREO

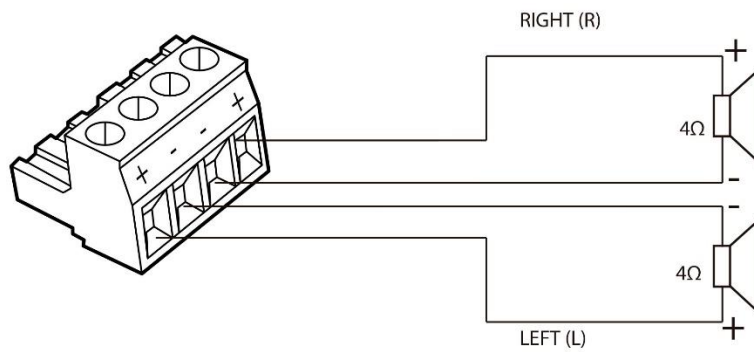

#### 3.2. MONO

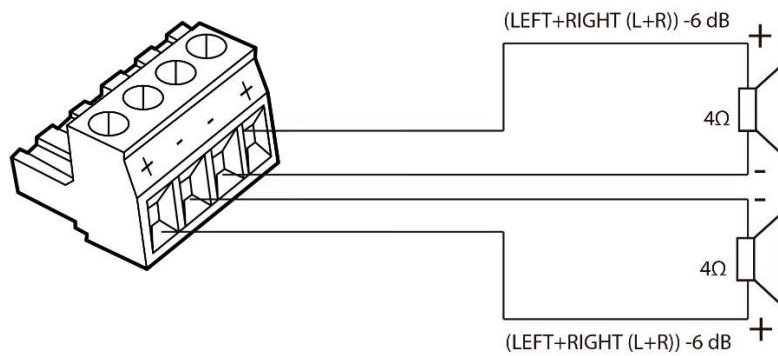

#### 3.3. BRIDGE

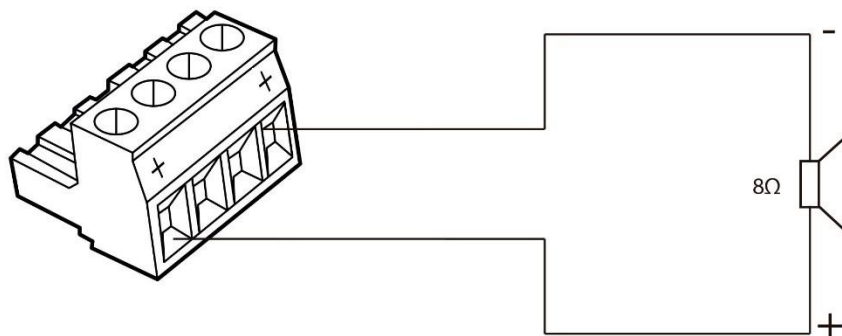

## 4. COMMUNICATION PROTOCOL & COMMANDS

Protocol: RS232 9600 / 8 / N / 1

COMMAND	FUNCTION	FEEDBACK
1A1.	To select Input 1	A: 1 -> 1
2A1.	To select Input 2	A: 2 -> 1
0A0.	To mute MIC input and LOOP output	Mute
1A0.	To mute MIC input	Mute MIC
2A0.	To mute LOOP output	Mute LIN
0A1.	To unmute Audio	Unmute
3A0.	To activate Noise Gate	Gate On
4A0.	To deactivate Noise Gate	Gate Off
600%	To check working status	A: 2 -> 1 (example) Volume of MIC : 48 Volume of LINE : 50 Bass of LINE : 3 Treble of LINE : 2
601%	Increases MIC level (+1)	Volume of MIC: xx
602%	Decreases MIC level (-1)	Volume of MIC: xx
603%	Increases LINE level (+1)	Volume of LINE: xx
604%	Decreases LINE level (-1)	Volume of LINE: xx
605%	Increases BASS level (+1)	Bass of LINE: xx
606%	Decreases BASS level (-1)	Bass of LINE: xx
607%	Increases TREBLE level (+1)	Treble of LINE: xx
608%	Decreases TREBLE level (-1)	Treble of LINE: xx
609%	Initialization, back to the default settings	Init OK
5[x][x]%	To set MIC level (00-60)	Volume of MIC: xx



COMMAND	FUNCTION	FEEDBACK
7[x][x]%	To set LINE level (00-60)	Volume of LINE: xx
8[x][x]%	To set BASS level (00-08)	Bass of LINE: xx
9[x][x]%	To set TREBLE level (00-08)	Treble of LINE: xx

**Examples:**



Dots must be included in the String

**Example 1:**

Select Input 2: 2A1.

**Example 2:**

Increases in one step Line Input level: 603%

**Example 3:**

Set MIC Input level to 21: 521%

**Example 4:**

Checking the working status: 600%

## 5. ACCESSORIES

### Included

PBA 60H includes two wings for mounting on a wall and its 4 fixation screws.

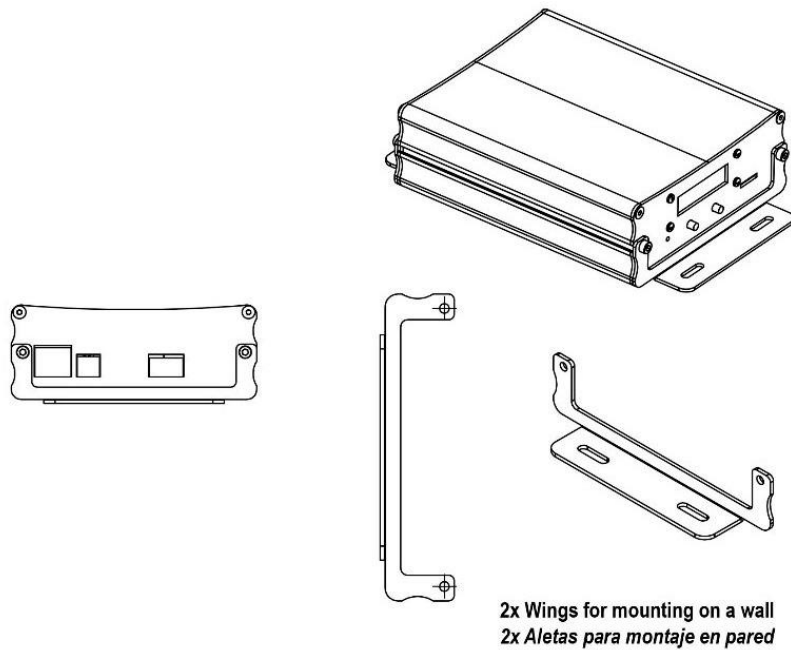

### Optional

#### BL AR 19

Fixing accessory for standard rack 19" 1 HU to house up to 4 PBA 60H devices or integrate with several Blueline MKII series units.

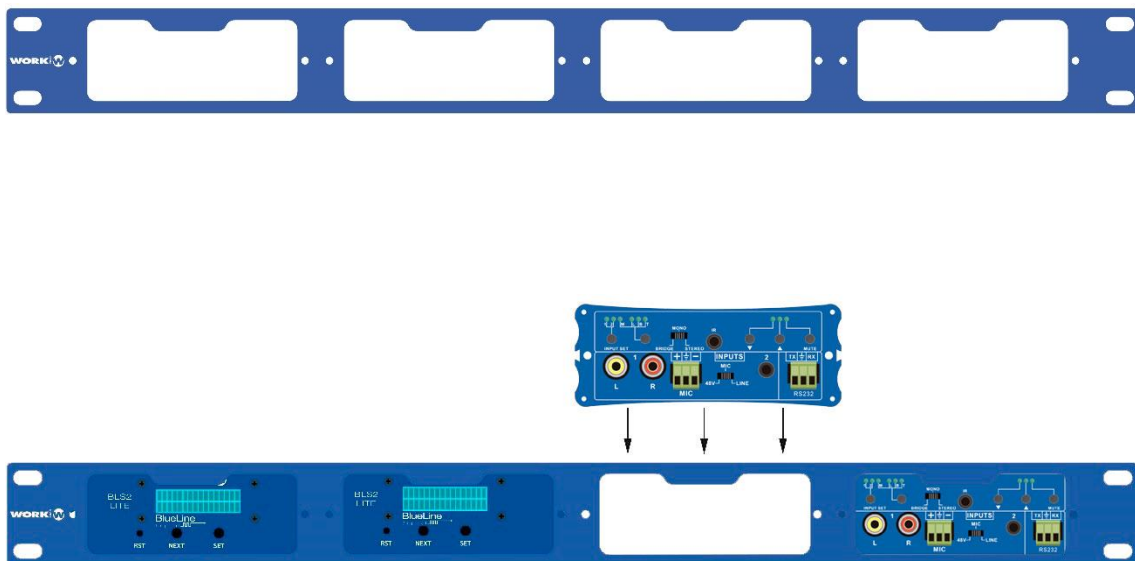





**Av. Saler nº 14 Polígono. Ind. L`Alteró. Silla 46460 VALENCIA-SPAIN**

**Tel: +34 96 121 63 01**

**[www.workpro.es](http://www.workpro.es)**